

Construction

90 plus complex syntax

2-page opening with side panel



Materials

It is recommended that PODD books constructed for **direct pointing access** are **laminated using 80micron laminate**. Waterproof paper and thinner laminated pages are not recommended for anyone who slides their hand across or pushes onto the page when pointing as the pages move or scrunch up making it very difficult to read the point and eventually become damaged. Communication may also break down for individuals with additional sensory processing challenges if they “fiddle with”, flick or scrunch pages to seek additional sensory input. Thinner laminate or waterproof paper is only recommended for direct access when the individual has a very light, hand on and off, point and no additional sensory processing challenges.

DO NOT USE laminate thicker than 80 microns for any PODD communication book. PODD books have many pages to laminate and they can become heavy and unwieldy if thicker laminate is used. Even a few extra microns on each page can significantly add to the weight and thickness of the whole communication book. **Matt finish laminate** is recommended to reduce glare on communication book pages.

This two-page opening plus side panel PODD communication book works best when the pages do not fold back over the spine of the book when the book is held open. **Comb binding is recommended** to provide a more stable page opening when the book is held in one hand by the partner or rested on the lap for direct pointing access. **DO NOT put the pages in a ring binder or bind with rings, cable ties or spiral coils** (see information on binding).

Materials & Equipment List

- Computer
- MIND Express®
- PODD® templates for Mind Express®
- Colour printer
- Laminator
- Scissors or blade knife (Stanley knife)
- Ruler

- Glue stick
- Comb binding machine and one 32mm binding comb
- Cloth duct tape
- 1 small Velcro® dot (hook & loop)
- A4 plain paper
- A4 Label stickers - one label per sheet (approximately 18-20 sheets*)
- Matt 80 micron laminating pouches (approximately 82-85 pouches*) OR Matt 80 micron laminate roll

To make a plastic covered book

1. Thick plastic to make two covers sized 16cm x 23cm and either one side panel sized 23cm x 11cm or one side panel with all categories sized 23cm x 13cm (E.g. covers of plastic pocket books)
2. 3 x A4 label stickers - one label per sheet (extra)

To make a cardboard covered book

3. Thick coloured cardboard to make two covers sized 16cm x 23cm and one side panel sized either 23cm x 11cm or with all categories. sized 23cm x 13cm

To make the optional school section topic pages

- 2 clear plastic letter files and sheets of A4 plain paper

* The precise number of pages will vary depending on individual customisation.

Preparing PODD book pages for printing

To print the PODD book pages in the correct order you will need to move the location of some pages in the main menu of pages (*page settings*).

- 1) Go to Menu > Edit (or press the F2 key)
- 2) Choose the Page tab at the top of the edit panel
- 3) Select the page settings icon (or press the F8 key) to view all of the pages in the *Page settings* window.
- 4) Check that your selected optional pages have all been moved into the main page set into the correct location and all unwanted pages with duplicate page numbers have been deleted (see instructions *to view, select and re-order options pages in Mind Express* in the Information file for 90 plus complex syntax.)
- 5) **Check all the pages are in book order using the PODD book page numbers** (ignore the Mind Express numbers). If required drag & drop, cut or copy & paste pages into their correct location (using the PODD book page numbers).

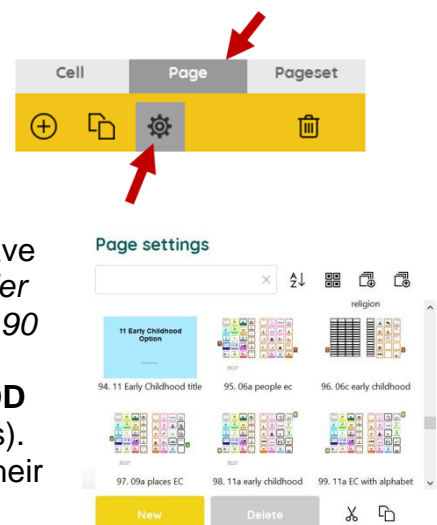

Create A Printable One-Page View Version

In Mind Express both sides of a PODD book page opening were displayed together for easier viewing and customization. To print the book, **you need to change the current two-page view into a single-page view version that is optimised for printing. DO NOT print before this step.**

To generate the single-page view version:

- 1) In edit mode, use the navigation bar at the bottom of the screen to go to the first *Menu* page.



- 2) Switch to User Mode by selecting Menu > Done edit (or press the F2 key)
- 3) Select the green button *Create Printable One-Page View Version*. **Select the button only once and wait.** The process will take a few minutes.

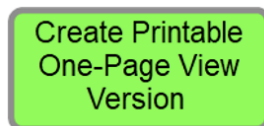

- 4) At the end, you will be instructed to save the file with a new name (Print + name of individual and date of file version are recommended).

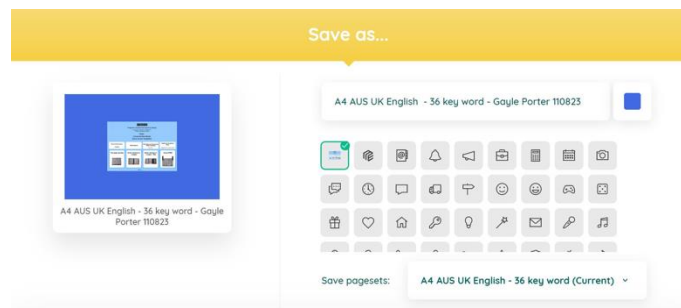

Hide unfilled LIST cells

Later in the construction process you will print LIST cells onto stickers to attach over the top of the laminated page (so they can easily be written on with any pen, pencil or marker). It is helpful to hide unfilled LIST cells from the main book pages before printing so the lines do not show through the sticker.

To do this:

- 1) In edit mode (Menu > Edit or F2 key), navigate to the first menu page.
- 2) Exit Edit mode (Menu > Done Edit or F2 key)

- 3) Select the button *List Cells Invisible* (this hides unfilled LIST cells for printing)

Printing

There are two options for printing this two-page opening book in Mind Express.

- 4) Printing single sided and then cutting and & pasting the pages back-to-back
- 5) Printing double sided

The following issues must be managed when printing and constructing a two-page opening PODD book

- 1) The variation in the default paper size/margin settings for different printers has made it impossible to create a template layout that will accurately align the edges of the front and back of the page on different printers.
- 2) The ordering of the pages in the Mind Express templates requires concentrated effort to ensure that the pages print or are pasted so that the front of the page is correctly matched with its corresponding back (as it appears in the bound communication book).

Check Alignment

Mind Express has included a function to change the off-set of the pages to help manage the variation in printer margins. **You will need to do a test print on your printer to check the alignment.** To do this:

- 1) The first page displayed after you create your *one-page view version for printing* includes instructions for checking the alignment and a 'Change offset button
- 2) Select Menu > Print > Page and, without changing anything, select the OK button in the Print settings window

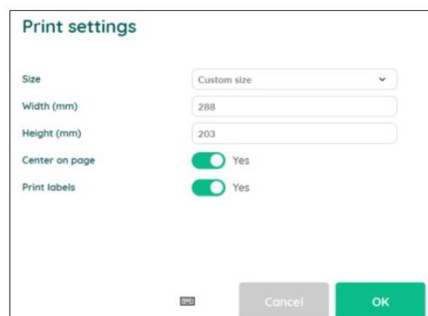
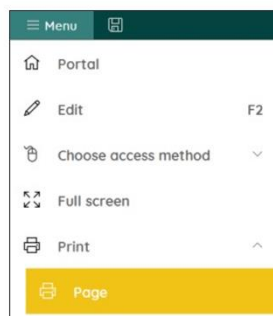

- 3) Choose which printer to use and then select the Preferences button. Confirm A4 as document size, Portrait as orientation.
- 4) In your printer preferences select double-side or single sided printing to suit your preference.
- 5) To test the alignment, select the print range 7-8 (Note these are the Mind Express assigned page numbers, not the PODD book numbers). Select to Print.

- 6) Check the alignment of the side lines and tabs between the front and the back of the page.
- 7) If the alignment is off, use the change off-set 'minus' and 'plus' button to move the whole page left or right. Select Apply.
- 8) Repeat steps 5-7 until your side lines and tabs are in alignment. (Note: some printers will not allow a perfect alignment but get as close as you can.)
- 9) Once you have figured out the correct offset value for your printer, that value will be automatically applied to all the pages in the book.

Offset

-	0	+
---	---	---

Apply

Reminder: Do not change the settings in the print window for this book.

Printing main pages

01 main to 24b topic, plus any optional pages.

NOTE: the following pages are attached to the cover and side panel in this PODD book

- ✓ 00 side panel
- ✓ Instructions back cover
- ✓ 01 main (1) – the left side of 01 main.

If using a **plastic** cover, these pages will need to be printed onto **stickers**.

If using a **cardboard cover**, these pages will need to be printed onto **paper**.

Load your printer with **A4 paper**.

- 1) Go to Menu > Edit (or press the F2 key)
- 2) Choose the Page tab at the top of the edit panel. Select the page settings icon (F8 key) to view all of the pages in the *Page settings* window.
- 3) Scroll to the last page in the PODD book – *24b topic (2)* in an unaltered page set (or *23b alphabet (2)* if no school setting has been selected). Write down the Mind Express number associated with this PODD book page.
- 4) Scroll to *Instructions back cover* then write down the Mind Express number associated with this page.
- 5) Scroll to *00 side panel* then *01 main (1)*. Write down the Mind Express numbers associated with these PODD book pages.
- 6) Switch to User Mode by selecting Menu > Done edit (or press the F2 key)
- 7) Select Menu > Print > Page and, without changing anything, select the OK button in the *Print settings* window
- 8) Choose which printer to use and then select the Preferences button. Confirm A4 as document size, Portrait as orientation.

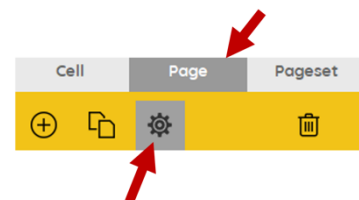

If printing Double sided.

- a. Select Menu > Print > Page. In your printer preferences select one-sided printing then select to print the Mind Express page number you identified in step 5 for *00 side panel*.
- b. If using a **cardboard cover**, in your printer preferences select one-sided printing then select to print the Mind Express page number you identified in step 5 for *01 main (1)* (if using a **plastic cover, omit this step**).
- c. Then select Menu > Print > Page again. In your printer preferences select 2-sided printing and set the print range to 4 – (the Mind Express number you identified for the last page of the PODD book at step 3 above).

If printing single sided (to cut and paste pages back-to-back)

- a. If using a **cardboard cover**, in your printer preferences select one-sided printing and set the print range to 2 – (the Mind Express number you identified for the last page of the PODD book at step 3 above).
 - b. If using a **plastic cover**, in your printer preferences select one-sided printing and set the print range to 4 – (the Mind Express number you identified for the last page of the PODD book at step 3 above).
- 9) If using a **cardboard cover**, Print the *instructions back cover*. (Check that the instructions are correct for the individual and that you have inserted their contact number.) Select Menu > Print > Page again. In your printer preferences select one-sided printing and set the print range to (the Mind Express number you identified for the *instructions back cover at step 4 above*).

Printing Lists and other pages on stickers

Load your printer with **A4 stickers** (printer labels with one label per sheet).

- 1) In Edit mode (Menu > Edit or F2 key), navigate to the first menu page.
- 2) Exit Edit mode (Menu > Done Edit or F2 key)
- 3) Select the button *List Cells Visible* (this shows all LIST cells for printing)
- 4) Go to Menu > Edit (or press the F2 key)
- 5) Choose the Page tab at the top of the edit panel. Select the page settings icon (F8 key) to view all of the pages in the *Page settings* window.
- 6) Scroll to the *list for sticker* pages (located at the end of the PODD book, before the options). Write down the Mind Express numbers associated with the range of LIST stickers you require to suit your options.
- 7) Switch to User Mode by selecting Menu > Done edit (or press the F2 key)
- 8) Select Menu > Print > Page and, without changing anything, select the OK button in the *Print settings* window
- 9) Choose which printer to use and then select the Preferences button. Confirm A4 as document size, Portrait as orientation.

1. Put all the pages in order except the *00 side panel*, *left side of 01 main* and *instructions back cover*. It is helpful to arrange the pages as they will be glued and cut to make the book, i.e. *left side of 01b* turned over behind (to paste on back of) *right side of 01a*; *left side of 02a* turned over behind (to paste on back of) *right side of 01b*; etc.
2. Take page right side page of *01a main* (*01a* with tab on the right hand side) and *01b left* (*01b* with tab on the left hand side). Align the outside lines and tabs - you may be able to see through the paper - then glue the pages back to back using a glue stick.

TIP Make sure you match the tab edges of the page – not the edges of the paper when you glue. Varying printer margins change the relative position of the board on the paper causing misalignment of the front and back of a cut page.

TIP If you are having difficulty aligning the outside page edge lines and tabs you may choose to cut out both pages prior to gluing. This method requires double the cutting but some people find it easier than matching the uncut pages.

3. Next take page *01b right* (*01b* main with tab on the right) and *02a left* (*2a opinions* with tab to the left), align the lines and tabs and glue them together back to back.
4. Continue gluing pages back-to-back, checking that the tabs line up, until all of the pages are glued together.

Cutting the pages

With double-sided printed pages, or when all the single printed pages have been glued together, cut along the black line of the page edge and around the tab on each page. (See diagram below)

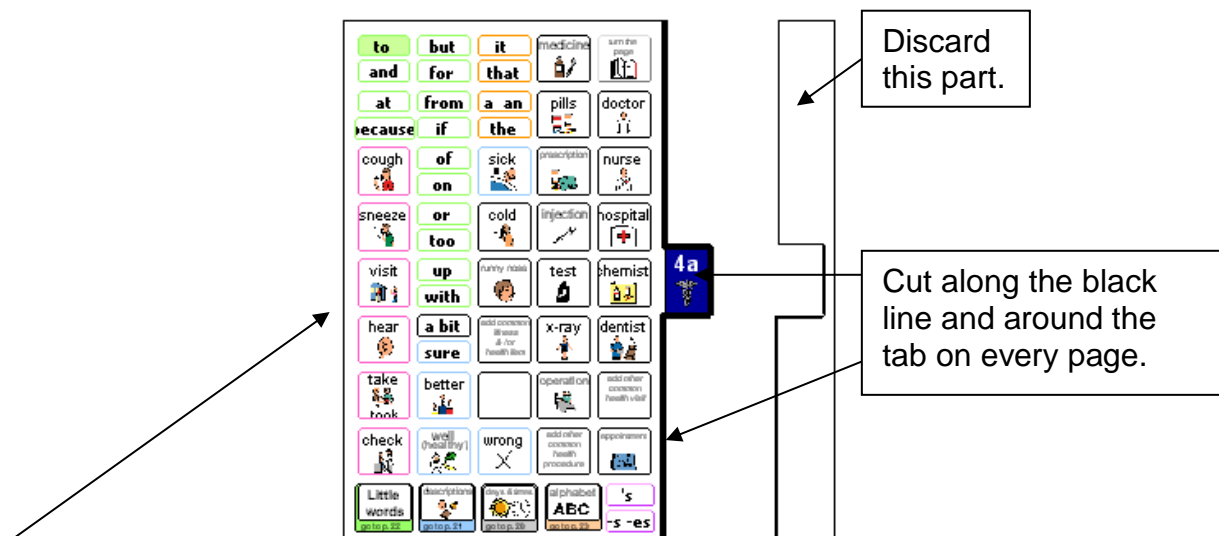

Depending on your printer margins there may be a small hangover of one or the other pages on the edge opposite the page tab. As this edge will be bound it usually does not alter either the appearance or functionality of the communication book. You may choose to trim this page edge.

Laminating the Page Set

Important information re: Laminate thickness

PODD communication books have many pages to laminate and they can become heavy and unwieldy if thicker laminate is used. Even a few extra microns on each page can significantly add to the weight and thickness of the whole communication book.

DO NOT USE laminate thicker than 80 microns.

1. Laminate all of the cut out pages, up to 20f weather.

Note: Only the left side of the optional page *21a topic is laminated* (on the back of *20f weather*). **Do not laminate** the right side of *21a topic* and *21b topic* as these will be placed in heavy duty clear plastic sleeves.

2. Cut out each page leaving a 3-5mm border of sealed laminate around the edge of each page. Round off the corners.

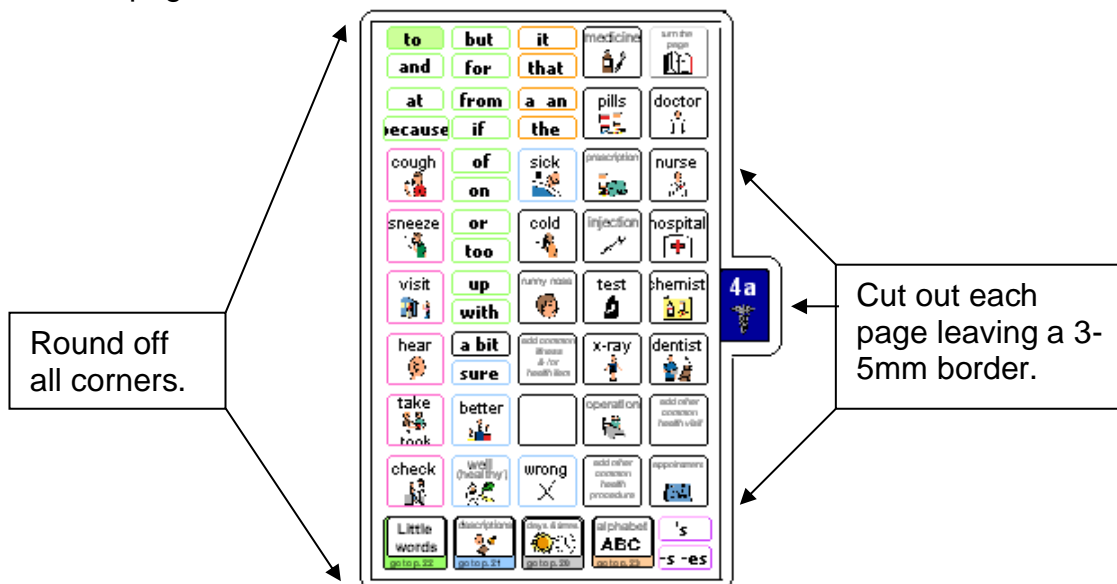

If you are going use plastic cover (see information below)

Laminate the whole sticker for pages *00 side panel*, *left side of 01 main* and *Instructions for back cover*. You will cut these out when you are making the cover.

If you are going use cardboard cover you will laminate these pages after you glue them onto the cardboard cover (see information below)

If you are going use the optional **22b with swear pages**, cut out and laminate the cover for swear words sticker (*list 08 with swear*). Remember to make sure the sticker includes all the pictures you have selected to represent swear words on the cover (the text is on the page underneath the cover so that it cannot be viewed until the user instructs their partner to lift the flap).

Adding the Lists

You should have 6-8 pages of lists printed onto A4 stickers, labelled with their page numbers.

TIP Most stickers have an edge from which it is easiest to peel the backing. Try to leave this edge intact when you cut out the list. Do not cut on the lines of each list, cut very close to the edge but leave the lines intact.

1. Leaf through the book until you find a page, which has had its lists, deleted. The first page should be *02b opinions left*. (See below)

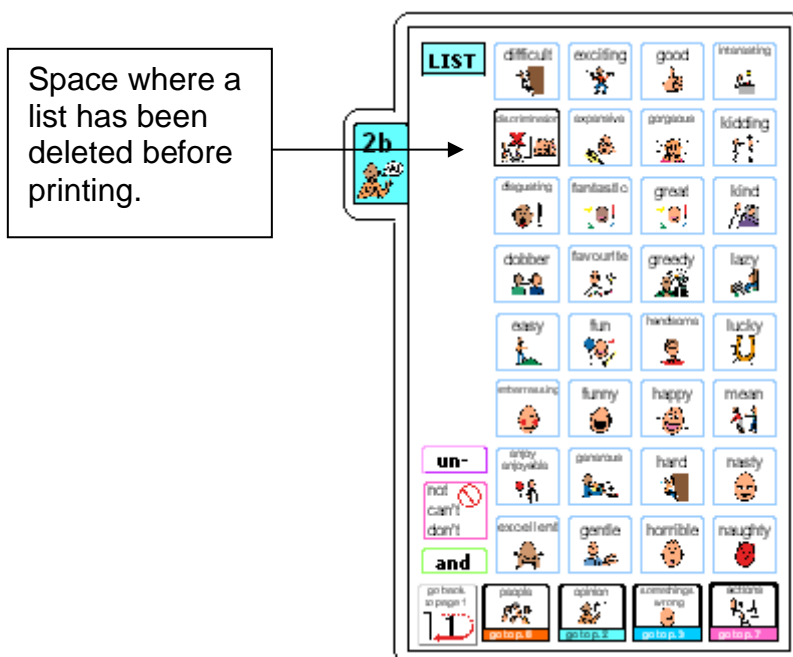

2. Locate the list labelled **2b** on the sticker. Cut it out leaving its edges intact and any part of the sticker that will make the list easier to peel off the backing sheet. Note you may already have filled in some list cells when customising the book. Cut the LIST sticker to size for blank cells only.

Cut out list for page 2b leaving its edges intact and part of the leading edge.

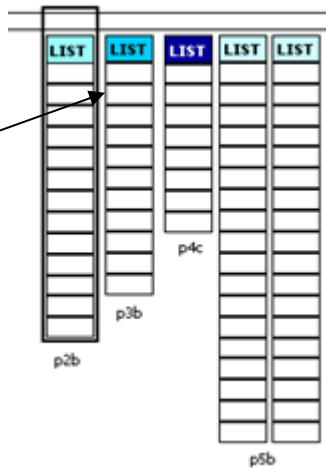

3. Peel off the back of the list and cut off any excess sticker. Stick it on to the laminated page. If you are unsure about where to stick the list, open page the corresponding template page on your computer to see what it should look like.

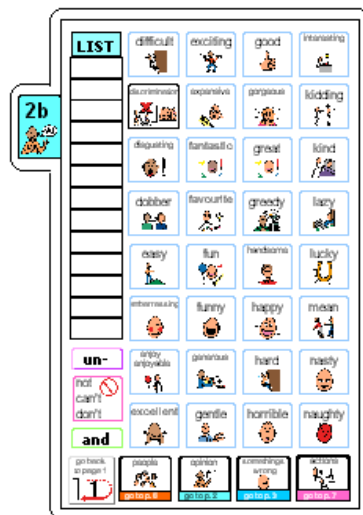

TIP Do not cover any list cells that already have words in them.

4. Leaf through the book until you find the next page with its list deleted, cut and add the appropriate sticker. Repeat the process until you get to 07b.
5. 7b - 7k actions. Measure or estimate how many cells it will take to fill each gap on the action pages. Cut out a block of cells to fill the gap, peel off the back and stick the block of cells in the gap on the page. It may be easier to cut off strips of cells, peel off the back and then cut them to size. Continue until all the gaps in the actions section are filled. If you are unsure about where to stick the list open the page in the Mind Express® software to see what it should look like.
6. Continue finding the spaces for lists and adding list stickers until you have added stickers to all list spaces in the communication book.

Special Pages

There are 2 types of special pages that may be used in this PODD.

1. The topic pages *24a* and *24b* are not laminated but slide into clear plastic letter files so that they can be easily removed and to be written on as required.
2. The optional *22b little words / swear page*. This page has discretionary flaps to cover the swear words.

Making the (optional) topic pages

You can add as many pages as you like for different topics. The instructions here are for one topic only.

You will need.

- Pages *24a topic right* and *24b topic left and right pages*.
- 2 clear A4 letter files (available from office supply stores)
- Scissors
- Ruler

1. Cut out a rectangle measuring 21.5cm height x 15.5cm width leaving the bottom of the letter file sealed and one vertical side sealed. (See below)

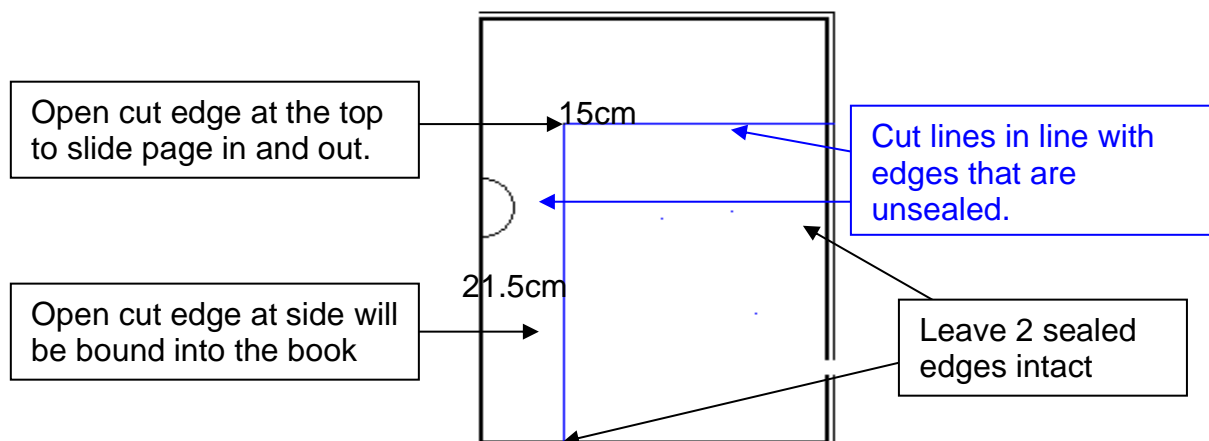

- Place the topic page in the plastic letter file with the tabs against the vertical sealed edge. The open side is the binding edge. Open at the top so the pages can slide in and out.

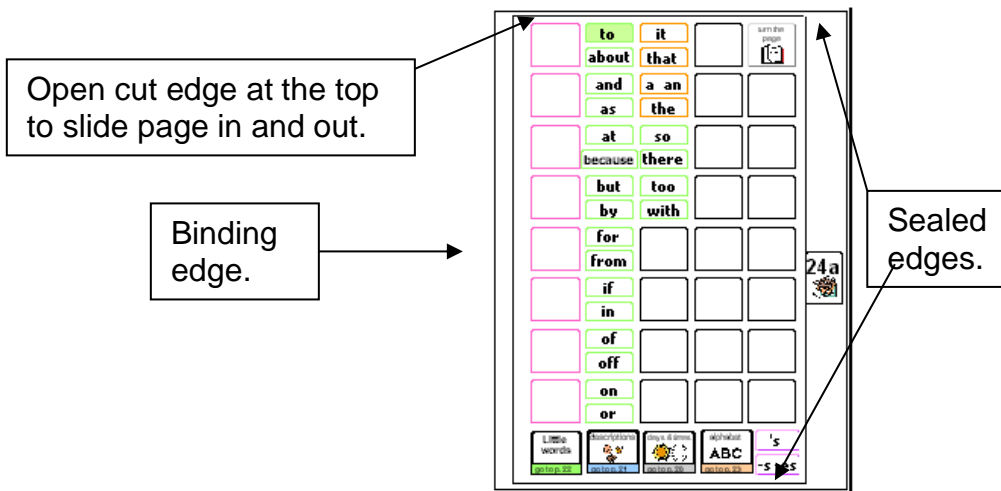

TIP Remove the page from inside the letter file when binding, so that the page can't get caught in the binding. Bind only the letter file.

Making the swear page

You will need:

- Pages *flap backers*, *cover for swear words* and *22b little words swear*.
- Scissors and blade knife (Stanley knife)

- Cut out the squares on the page labelled *flap backers* and put to one side.
- Take the laminated sticker *cover for swear words*. Using a razor knife, cut down the sides and along the bottom of each swear word cell. Marked in red on diagram.

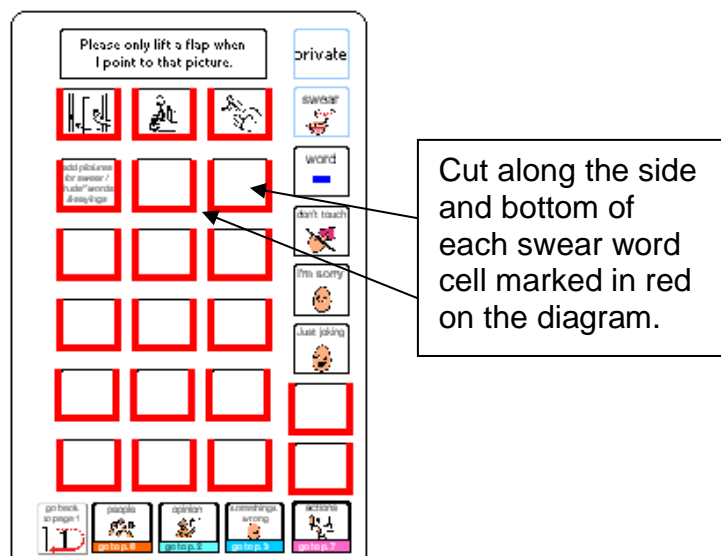

- Place the cut out *cover for swear words* page face down on the table. Carefully peel off the back of the stickers.
- Stick the flap backer squares to the back of each flap (cell). The purpose of this is to stop the flap sticking down when it is stuck on top of page 22b.

Back of cover for swear words.

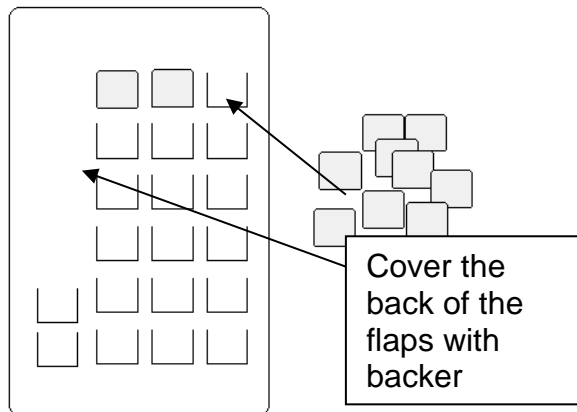

- Take the prepared *cover sticker* and position it on top of *page 22b left* so that the flaps fit over the matching cells below. Stick the cover down onto the page *22b left*.
- Flip open each cell. You may need to use the edge of a razor knife to do this.
- The *swear page* should look like the diagram below.



- You may wish to add a tiny Velcro® dot to each swear word cell and flap to ensure only the required swear word is displayed.

Making the covers

Instructions are included to use either a plastic or a cardboard cover.

Instructions for creating a plastic cover



4. Measure and cut 2 rectangles 16cm x 22cm from the thick plastic for the covers and either one side panel sized 22cm x 11cm or one side panel with all categories sized 22cm x 13cm (E.g. covers of plastic pocket books)
1. Round off any sharp corners.
2. Cut out the 3 laminated printed stickers, for pages *00 side panel*, *01a main* (left side only) and *instructions back cover*.
3. Peel off the back of the sticker named *01a main* and attach it to the inside of the front cover.
4. Peel off the back of the sticker named *Instructions back cover* and attach to the inside of the back cover.
5. Peel off the back of the sticker named *00 side panel*, trim leaving a small border and attach it 1cm in from the left edge of the smallest rectangle for the side panel.
6. Attach the *side panel*. Using the cloth tape, attach the *side panel* to the right hand side of the *back inside cover* where shown in the diagram below.
 - a. You need to make a 4cm soft folding edge out of cloth tape between the cover and the panel.
 - b. To make this folding edge wide enough, you may need to stick several pieces of tape together length ways to make a 6cm width.
 - c. Stick the tape to the cover's edge using 1 cm of tape on the outside right hand side of the cover. Then stick the side panel on the opposite edge of the tape, using 1 cm of tape. This should leave a 4cm soft folding edge. See diagram.

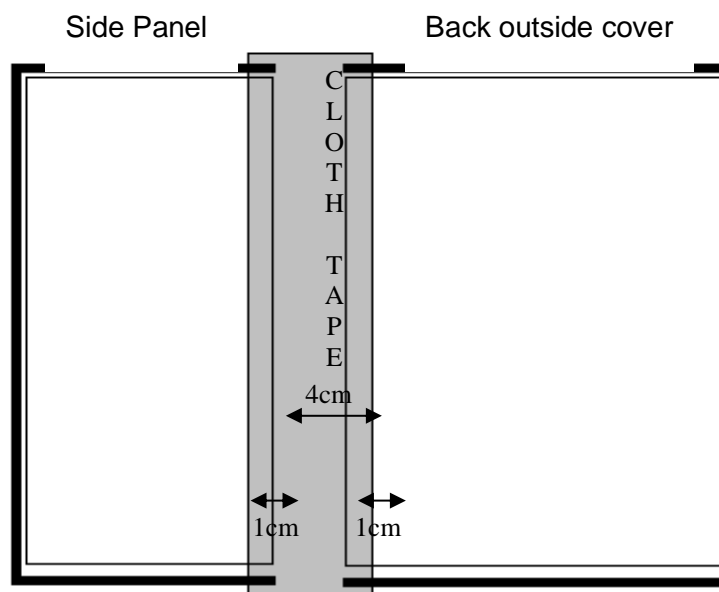

7. Turn the cover over and tape in the same place on the other side. Avoid covering print. Trim off excess tape.
8. Reinforce the edges. Use cloth tape to reinforce the edges shown by the dark line in diagram below. To do this:
 - a. cut a length of tape to suit length of the side you are reinforcing.
 - b. Position the tape very close to the printed cells and stick down.
 - c. Then fold the remaining tape over the edge of the cover and stick down on the other side.
 - d. Ensure you do not cover the printed text.

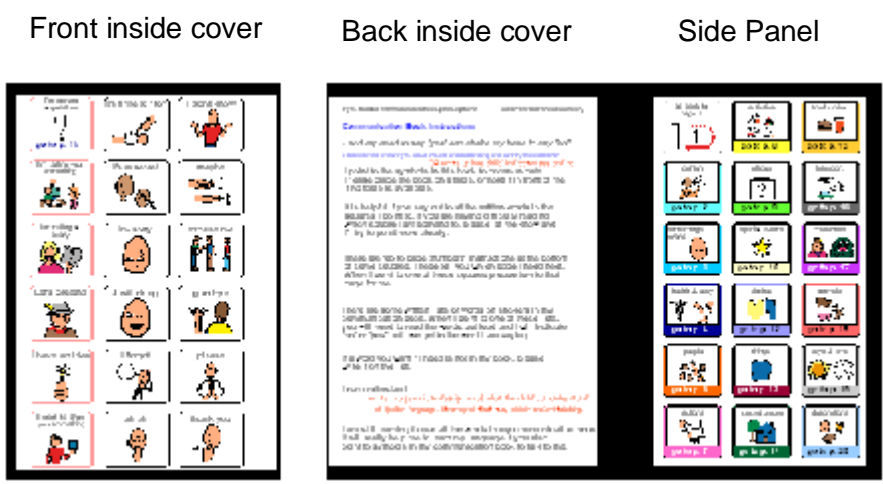

Instructions for a cardboard cover

If you are using plain cardboard and coloured paper, stick the paper to one side of the cardboard.

1. Measure and cut two rectangles 16cm x 23cm for the covers and one rectangle 13 x 23cm for the *00 side panel*.
2. Cut out the left side of *01a main* and glue it to the inside of the front cover.
3. Cut out the page named *Instructions back cover* and glue it to the inside of the back cover.
4. Cut out the page named *00 side panel* and attach it to the inside of the smaller (side panel) rectangle.
5. You may wish to personalise the book by decorating the outside of the side panel with pictures or the individual's name written in a fancy font.
6. Set your laminator to a hot setting and laminate the covers and side panel.
7. Cut around the laminate leaving a 5mm border of laminate on every side.
8. Attach the *side panel*. Using the cloth tape, attach the *side panel* to the right hand side of the *back inside cover* where shown in the diagram below.
 - e. You need to make a 4cm soft folding edge out of cloth tape between the cover and the panel.
 - f. To make this folding edge wide enough, you may need to stick several pieces of tape together length ways to make a 6cm width.
 - g. Stick the tape to the cover's edge using 1 cm of tape on the outside right hand side of the cover. Then stick the side panel on the opposite edge of the tape, using 1 cm of tape. This should leave a 4cm soft folding edge. See diagram.

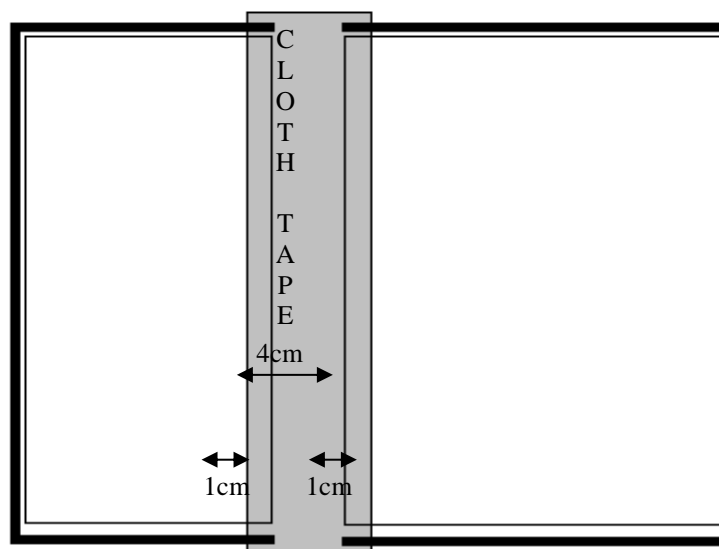

9. Turn the cover over and tape in the same place on the other side. Avoid covering print. Trim off excess tape.

10. Reinforce the edges. Use cloth tape to reinforce the edges shown by the dark line in diagram below. To do this:

- h. cut a length of tape to suit length of the side you are reinforcing.
- i. Position the tape very close to the printed cells and stick down.
- j. Then fold the remaining tape over the edge of the cover and stick down on the other side.
- k. Ensure you do not cover the printed text.



Front inside cover



Back inside cover



Side Panel

Binding

Comb binding is recommended for this style of PODD book.

Comb binding does not allow pages to bend back over the spine of the book. This creates a more stable surface for pointing when the book is held by the partner or rested on the lap. It also allows for easier movement for the communicator to point across the two pages on an opening without catching your hand on a binding or needing to lift your hand up off the surface to clear a binding in the centre of the page opening. Comb bindings do deteriorate with heavy use, however they are relatively easy to replace by schools and families (many schools have comb binding machines). Having to do routine maintenance is more desirable than selecting a binding that breaks down communication interactions on a daily basis.

DO NOT put the pages in a ring binder, bind with rings, cable ties or spiral coils.

A ring binder results in a wider book with the pages separated in the middle to the width of the spine of the binder. The laminated pages also tend to catch in the rings, causing the rings to open and pages to fall out.

Binding with rings, cable ties or spiral coils results in a book that folds back over the spine of the book when it is held open. This is not desirable in a two-page opening PODD book.

Comb binding

Before binding check your pages are in order. If using the optional school topic pages, add two **empty** plastic sleeves to the end of the book before binding (avoids the replaceable paper topic pages becoming caught in the binding).

Bind the PODD book pages according to your binding machine's instructions.

To make the comb binding more durable and stable, lock the binding and pull alternate teeth to the outside of the spine (i.e. one in and one out) and tape to the comb. Tuck excess tape around the ends of the binding comb.

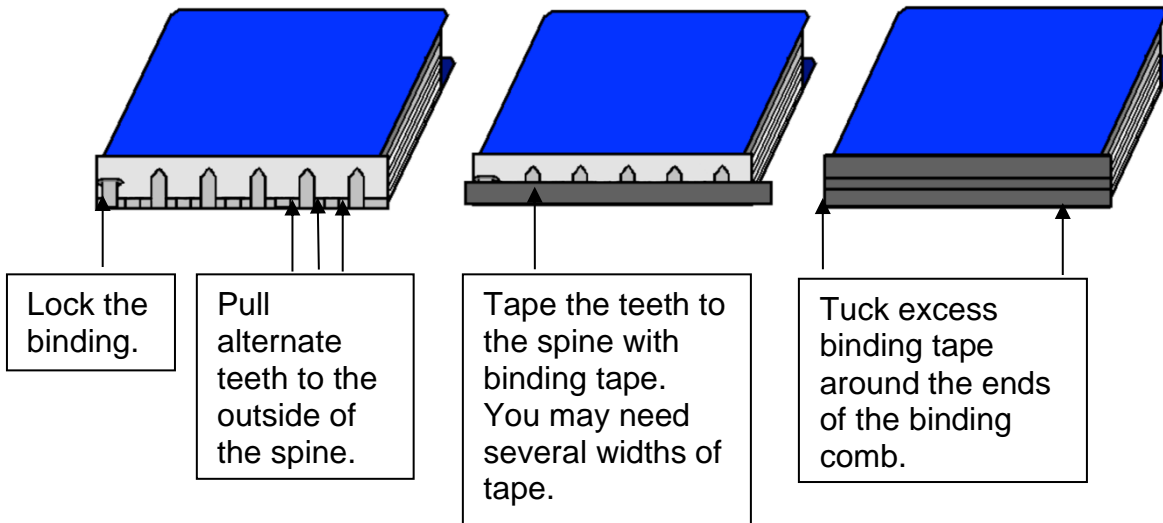

When not in use, the side panel folds around the tabs and is attached to the front cover with a Velcro® dot. To finish, add a small Velcro® dot to keep the book closed.

Side Panel



Add the soft side of a Velcro® dot here to keep the book closed when not in use.

Add the hard side of Velcro® dot to the corresponding place on front cover.